

Protection sensor against dry running

Sensor for detecting the presence of water based on the optoelectronic principle, therefore non invasive and with no moving parts. The sensor provides an electronic contact to be used to stop the pump in the event of a lack of water in the seal area. The sensor opens the electronic contact after a factory-set delay (10 secs).

The sensor is supplied in a kit complete with 2m of cable, a gasket O-ring EPDM, and a stainless steel adapter.

The sensor can also be used in the following applications:

- Checking the level in water buffer tanks.
- Checking the level in pressure tanks.
- Checking leaks.





General using features

- The sensor is suitable for being connected directly on the filling cap of pumps in the e-SV™ series. An adapter cap is supplied for the 33..125 series.
- Operation is independent of the hardness and conductivity of the water. The sensor is not suitable for detecting frozen liquids.

Available in different power supply versions:

- 21÷27 Vac, universal solid state output for 24 Vac external relay.
- 12÷28 Vdc, open NPN manifold outlet for Hydrovar inverter

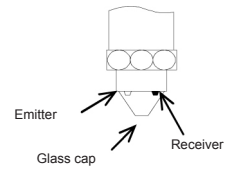
Operating principle

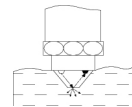
<p>Operation is based on the variation of the refractive index on the surfaces. The optic sensor comprises a glass cap with inserted a transmitter and an infrared receiver.</p>	
<p>Mirror effect. In the absence of fluid, all the infrared light emitted is internally reflected by the surface of the glass cap of the receiver.</p>	
<p>In the presence of fluid, the refractive index of the surface changes. Most of the emitted infrared light is dispersed in the fluid. The receiver receives less light, which causes the signal for presence of water.</p>	

For more information:
visit us at:
www.lowara.com

Characteristic data

- Materials:
 - Body in AISI 316L stainless steel
 - Glass optic cap
 - EPDM gasket
 - Maximum pressure (PN): 25 bar (higher pressures on request)
 - Fluid: clean demineralised water, independent of hardness and conductivity. Compatible with other fluids such as oils (*).
 - Liquid temperature: -20°C ÷ 120°C . Ensure that the fluid always remains above freezing point.
 - Ambient temperature: -5 ÷ $+50^{\circ}\text{C}$
 - Continuous duty
 - Alarm delay: 10 sec, set in the factory.
 - Connector: 3/8", included in the 3/8" – 1/2" adapter cap kit.
 - Protection degree: IP55
 - Electrical specifications:
 - Supply voltage: DC model: 12÷28 Vdc. AC model: 21÷27Vac
 - Sensor maximum absorption: 20mA
 - Load maximum absorption: 50mA
 - DC model outlet: NPN open manifold, maximum 28Vdc, 50mA.
 - AC model outlet: solid state outlet for general use in alternating current, maximum 21÷27Vac, 50mA.
 - Cable, included, type FROR 4x0.34 mm² (PVC – CEI 20-22) standard length 2m.
Cable working temperature -20 ÷ $+70^{\circ}\text{C}$, fixed installation.
 - Dimensions: 27x60 mm
- (*) To check suitability for operating with a fluid such as oil, contact the Lowara technical support service and supply the characteristics of the fluid.

Connection diagrams

Mechanical installation

The sensor may be fitted directly on the filling cap of e-SV pumps; for the series SV33..92, 125SV it is necessary to fit also a 3/8" – 1/2" adapting ring, included in the kit.

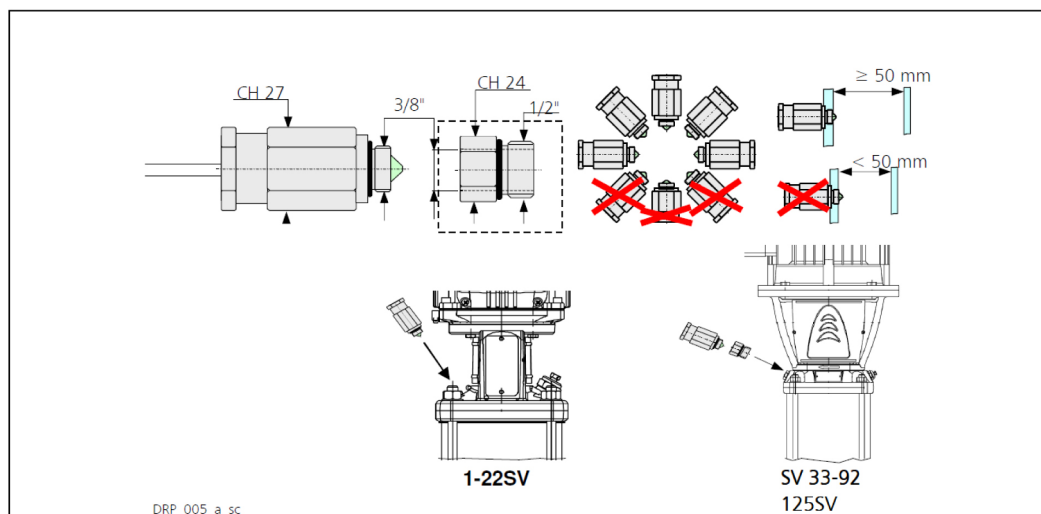

Connection diagrams

Direct current power supply 12÷28Vdc.

The sensor may be connected:

- To the Hydroval® directly on the terminal board X3. The sensor opens the NPN contact (black wire) 10 seconds (factory setting) after the water lack signal.

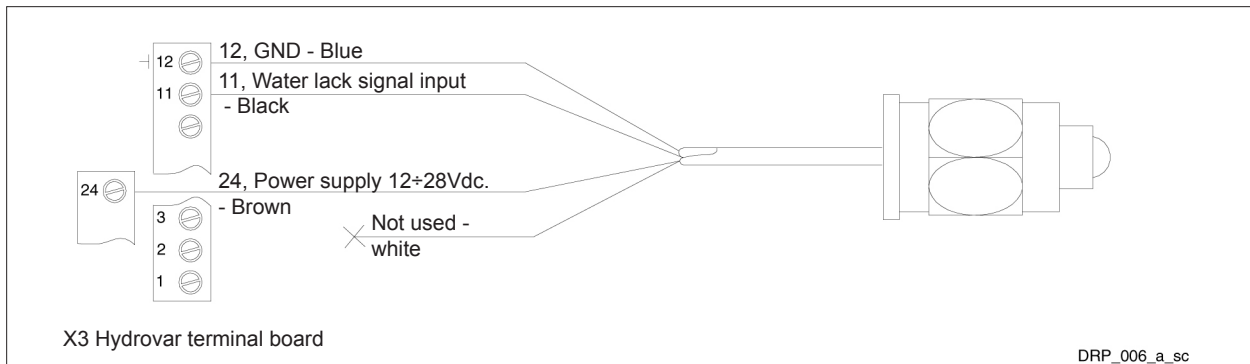

- To a monitoring system (PLC), directly on the terminal board. A load resistance (pull-up) with a minimum value of 1kOhm must be fitted on the outside.

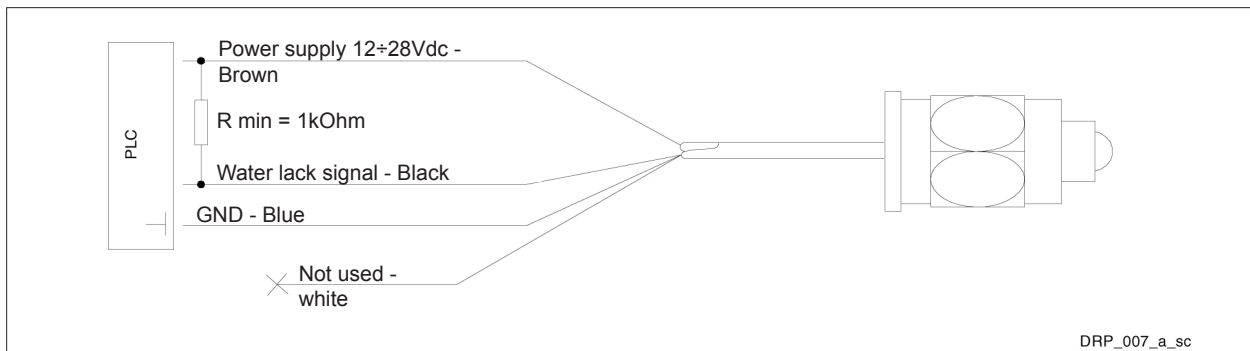

- To a system with a relay and direct current power supply. A recirculating (free-wheeling) diode must be fitted on the outside.

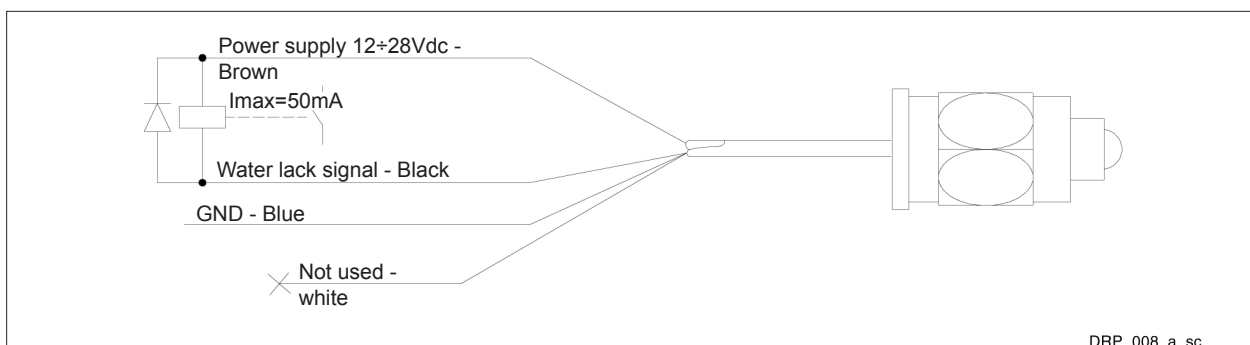



ITT

Engineered for life

General use, power supply 21±27Vac.

The sensor may be connected to a system with a relay and alternating current power supply.

